

PROJECT
OWNER
CONTRACTOR
DISTRIBUTOR
CONSULTANT
CLOW CANADA

350-500 R/W VALVE
BEVEL GEAR MATERIAL LIST
MODEL F6100
FUSION EPOXY - NSF 61 AND AWWA C550
COMPLIES WITH AWWA C515

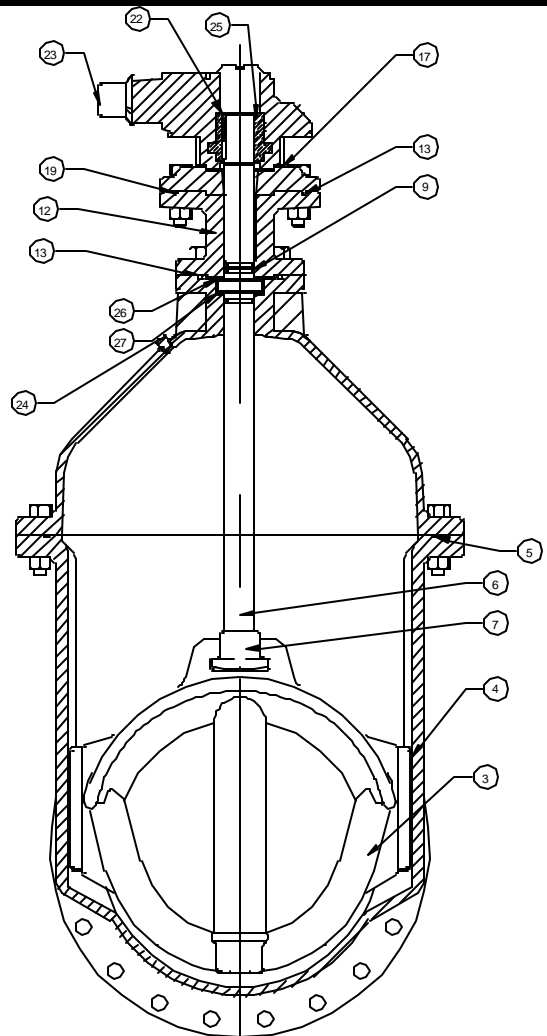
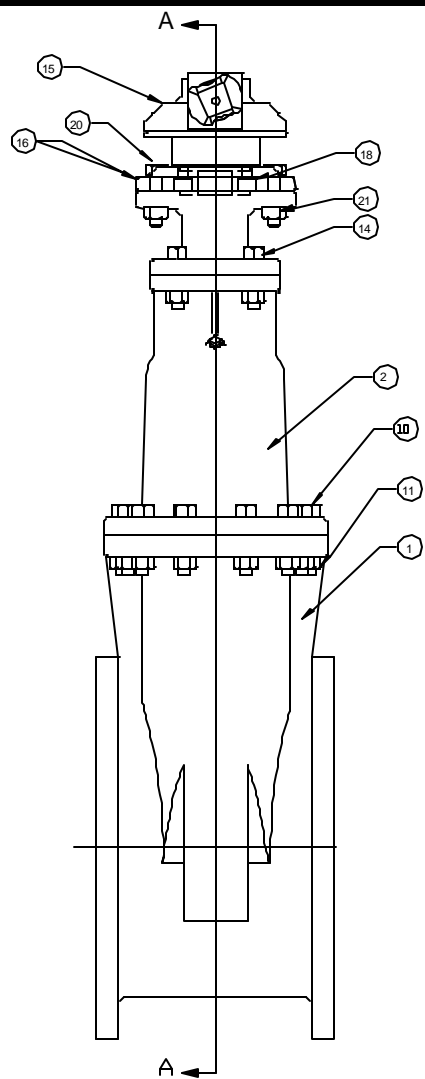

ITEM NO.	DESCRIPTION	MATERIAL	MATERIAL SPECIFICATION
1	Body	Ductile Iron	ASTM A536 65-45-12
2	Cover	Ductile Iron	ASTM A536 65-45-12
3	Wedge	Ductile Iron/Rubber	ASTM A536 65-45-12/SBR
4	Wedge Cap (18"-24" only)	Delrin	Delrin
5	Oring	Rubber	NBR
6	Stem	Bronze	ASTM B584 C86700
7	Stem Nut	Bronze	ASTM B584 C86700
9	Oring	Rubber	NBR
10	Hex Head Bolt	Zinc Chromate Plated Steel	ASTM A307 Gr B
11	Hex Nut	Zinc Chromate Plated Steel	ASTM A307 Gr B
12	Extension	Ductile Iron	ASTM A536 65-45-12
13	Oring	Rubber	NBR
14	Hex Head Bolt	Zinc Chromate Plated Steel	ASTM A307 Gr B
15	Actuator - 3:1 (18"-24") 2:1 (14-16")		
16	Adaptor Plate	Ductile Iron	ASTM A536 65-45-12
17	Actuator Gasket	Rubber	NBR
18	Socket Head Bolt	Alloy Steel	Alloy Steel
19	Oring	Rubber	NBR
20	Hex Bolt	Zinc Chromate Plated Steel	ASTM A307 Gr B
21	Hex Nut	Zinc Chromate Plated Steel	ASTM A307 Gr B
22	Key	Steel	-----
23	Op Nut	Ductile Iron	ASTM A536 65-45-12
24	Pipe Plug	Steel	Steel
25	Drive Sleeve	Steel	AISI 1023
26	Thrust Bearing	Delrin	-----
27	Thrust Bearing (18"-24" only)	Delrin	-----

2638-20
D 04/09/03