

2638-59
C 01/08/08

**30"-48" RW VALVE
SPUR GEAR PARTS LIST
CLOW VALVE COMPANY
MODEL 2638**

Item	Description	Material
1	Body - Mechanical Joint	ASTM A536 Ductile Iron
	Body - Flange	ASTM A536 Ductile Iron
	Body - MJ x Flange	ASTM A536 Ductile iron
2	Bolt - 7/8-9NC hex hd x 5-1/2 lg	AISI 304 Stainless Steel
3	Nut - 7/8-9NC hex	AISI 304 Stainless Steel
4	Wedge Casting	ASTM A536 Ductile iron
5	Molded Wedge	Rubber
6	Stem Nut	ASTM B763 alloy 995 Brass
7	Extension - actuator	ASTM A536 Ductile iron
8	Bolt - 3/4-10NC x 3" lg hex hd	AISI 304 Stainless Steel
9	3/4-10NC hex nut	AISI 304 Stainless Steel
10	Key	Square Seel Keystock
11	Actuator - spur gear	
12	O-ring	Rubber
13	Bolt - 3/4-10NC x 2-1/2 lg hex hd	AISI 304 Stainless Steel
14	Bushing - stem guide	ASTM B584 alloy 836 Brass
15	O-ring	Rubber
16	Thrust Bearing	Nylatron
17	O-ring	Rubber
18	Cover Bushing	ASTM B584 alloy 836 Brass
19	O-ring #236	Rubber
20	Cover	ASTM A536 Ductile iron
21	O-ring - cover outer	Rubber
22	Stem	ASTM B584 alloy 867 Brass
23	Pipe Plug - 3/4 NPT w/ square hd	AISI 304 Stainless Steel
24	Actuator Drive Bushing	Bronze
25	O-ring	Rubber
26	Wedge Protector	Delrin
27	Scraper	ASTM B148 C954 Al Bronze
28	Track	AISI 316 Stainless Steel
29	Roller	ASTM B148 C954 Al Bronze
30	Pln - roller	AISI 316 Stainless Steel
31	O-ring - cover inner	Rubber

2638-57
A 3-2-04

30"-48" RW VALVE
SPUR GEAR ASSEMBLY
CLOW VALVE COMPANY
MODEL 2638

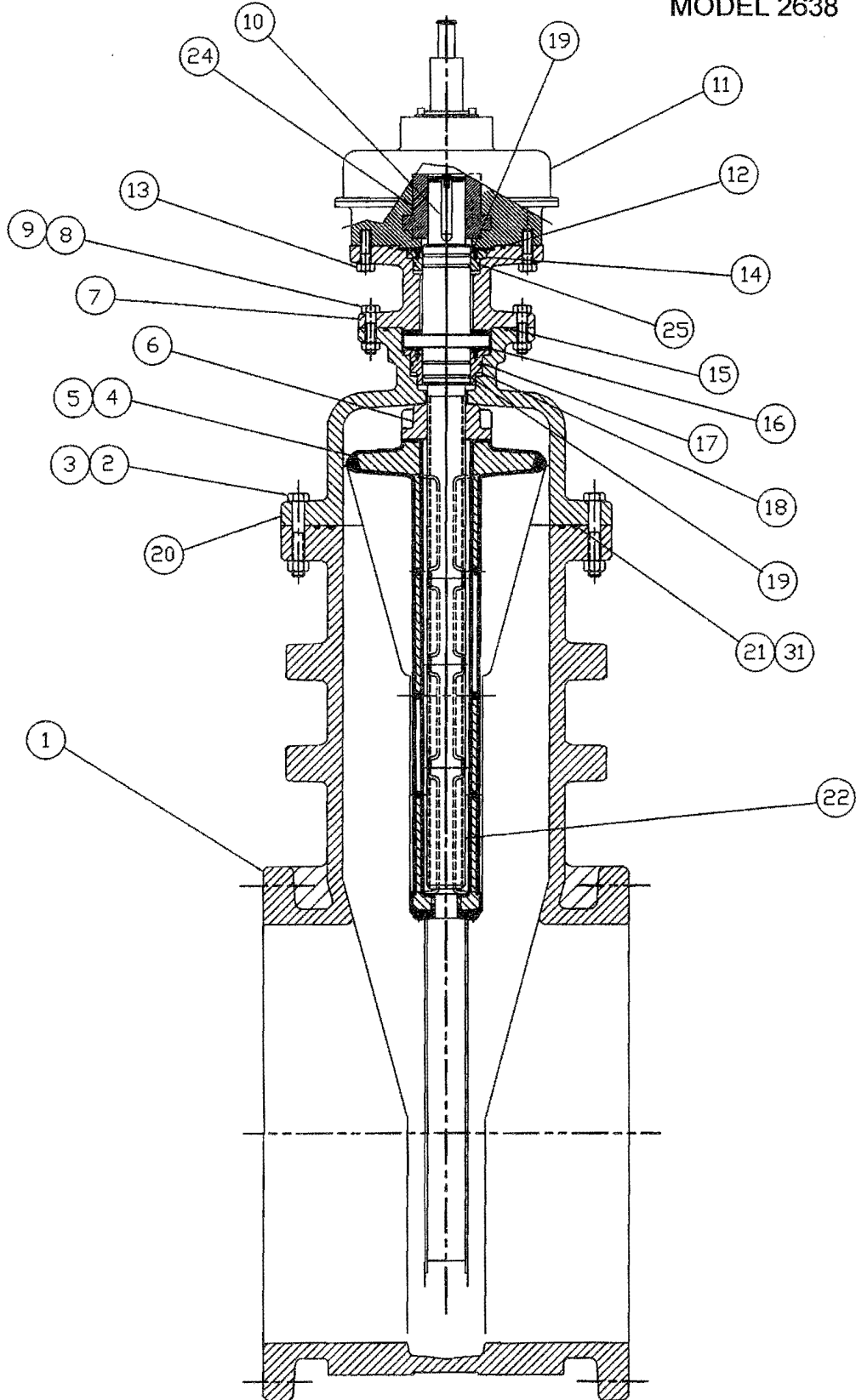

2638-58
B 1/14/08

30"-48" RW VALVE
SPUR GEAR ASSEMBLY
CLOW VALVE COMPANY
MODEL 2638

