

PROJECT	4"-12" R/W VALVE MECHANICAL CUT JOINT ENDS GENERAL DIMENSIONS MODEL F6100 FUSION EPOXY - NSF 61 AND AWWA C550 COMPLIES WITH AWWA C509
OWNER	
CONTRACTOR	
DISTRIBUTOR	
CONSULTANT	
CLOW CANADA	

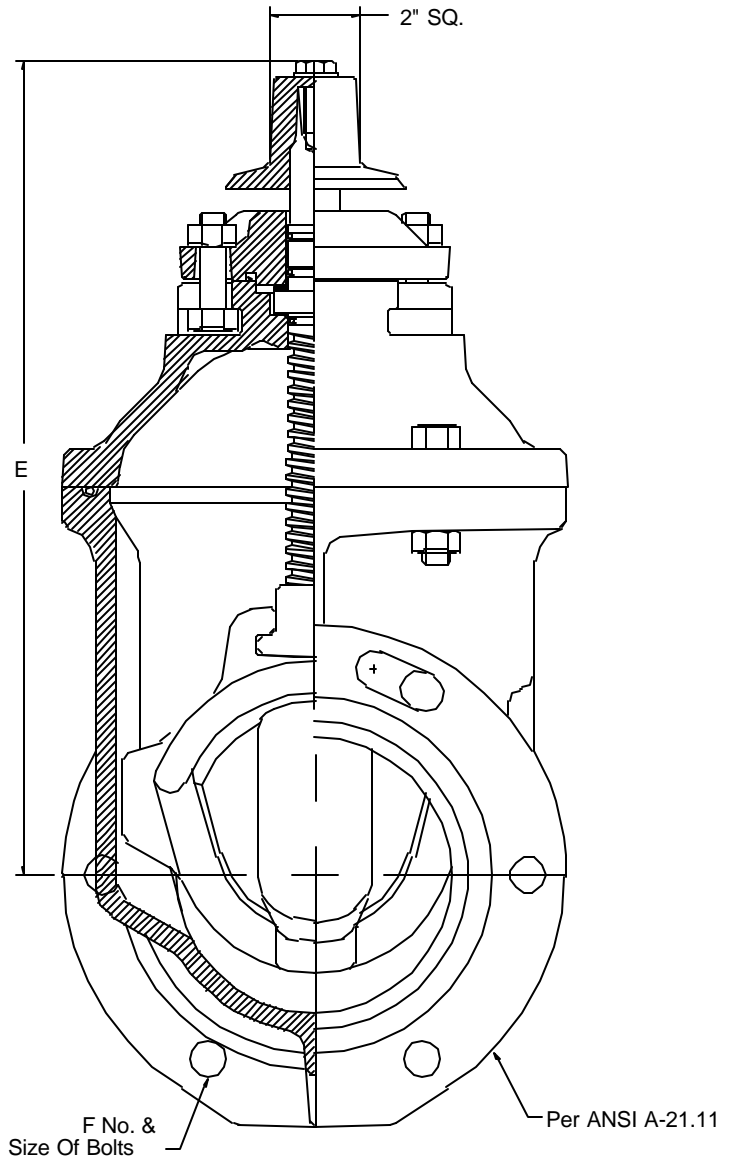
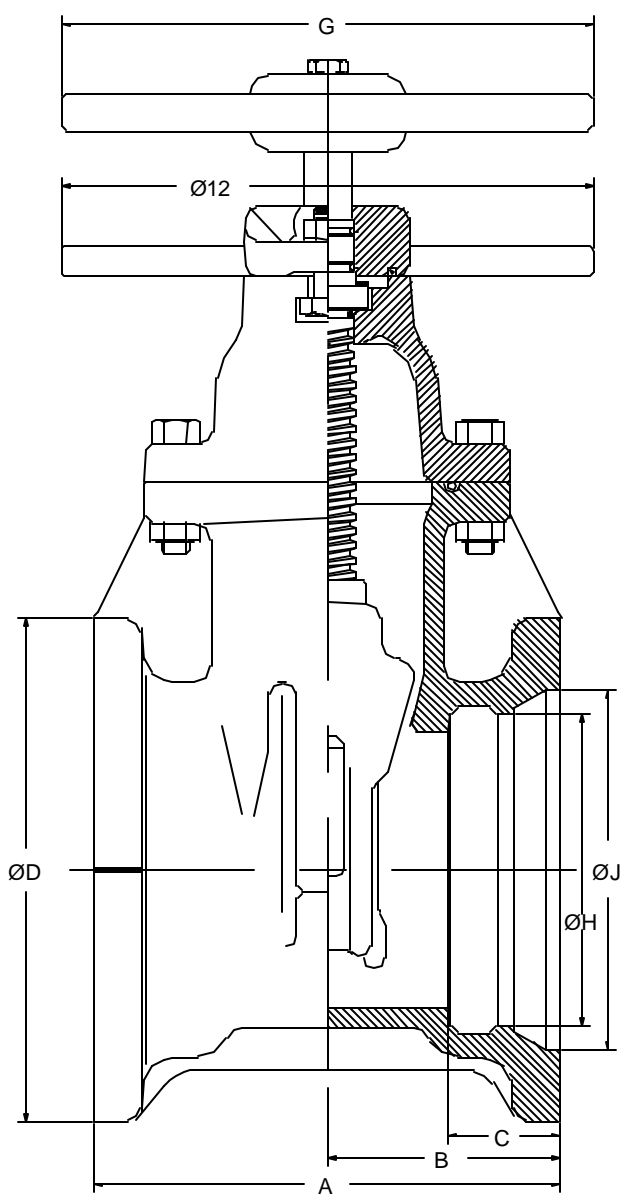

METRIC DIMENSIONS									
VALVE SIZE	A	B	C	D	E	F	G	H	J
100 (4")	241	121	64	232	375	4-3/4	250	130	157
150 (6")	267	134	64	283	483	6-3/4	300	183	211
200 (8")	333	167	64	350	572	6-3/4	350	239	267
250 (10")	394	197	64	400	673	8-3/4	450	292	320
300 (12")	406	203	67	457	762	8-3/4	450	345	374