

PROJECT
OWNER
CONTRACTOR
DISTRIBUTOR
CONSULTANT
<b>CLOW CANADA</b>

**14"-36" FLANGED GATE VALVE  
WITH SPUR GEAR**

**MODEL F5070 SG**

**FUSION EPOXY - NSF 61 AND AWWA C550**

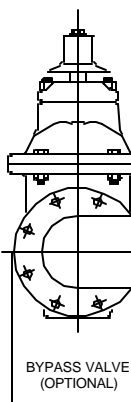
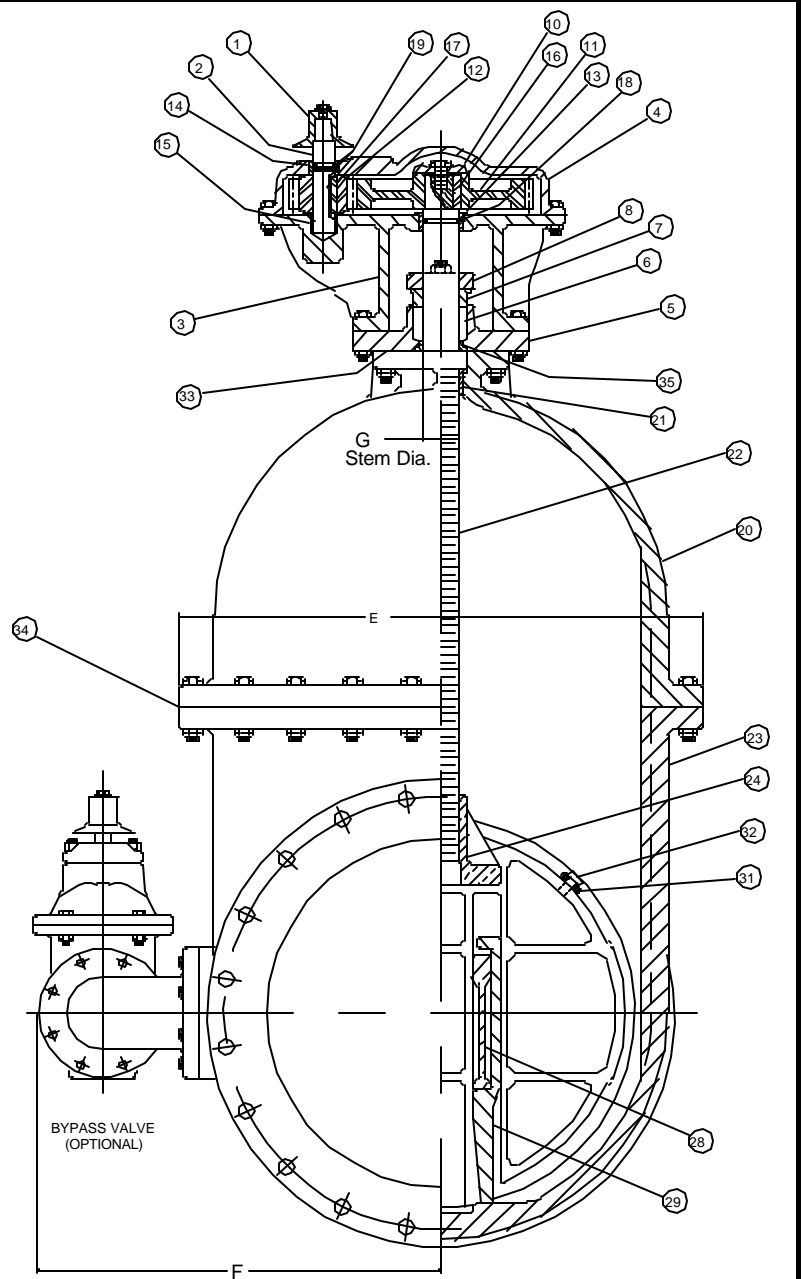
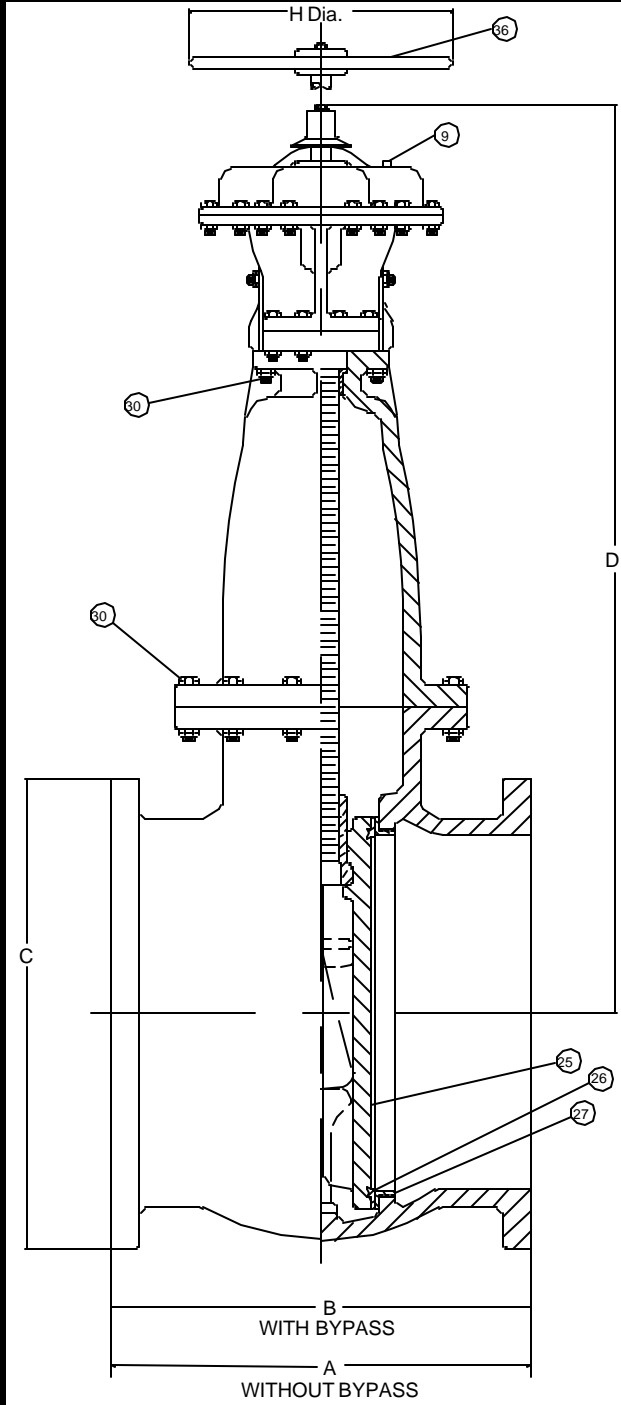

METRIC DIMENSIONS							
VALVE SIZE	350 (14")	400 (16")	450 (18")	500 (20")	600 (24")	750 (30")	900 (36")
A	400	432	483	508	584	635	686
B	584	584	610	610	724	825	914
C	533	597	635	600	813	984	1168
D	1143	1245	1324	1416	1578	1950	2245
E	600	654	705	835	908	1162	1429
F	489	520	572	610	711	800	1016
G	48	48	54	54	64	70	76
H	457	457	457	457	457	457	559