

PROJECT	50mm - 300mm R/W NRS FLANGED GATE VALVE MATERIAL LIST F6102 COMPLIES WITH AWWA C509 / ULC & FM FUSION EPOXY - NSF 61 AND AWWA C550
OWNER	
CONTRACTOR	
DISTRIBUTOR	
CONSULTANT	
CLOW CANADA	

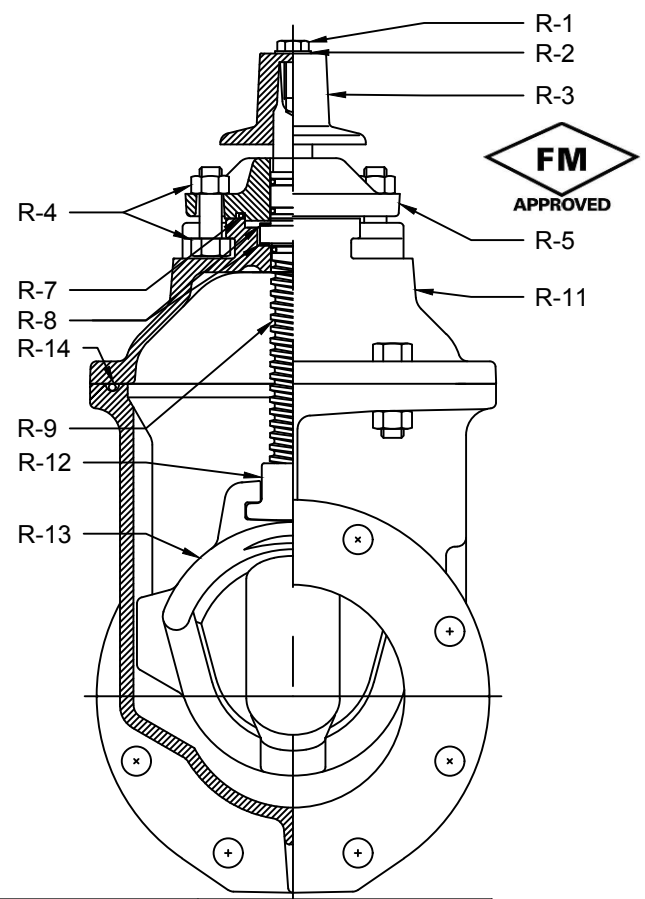
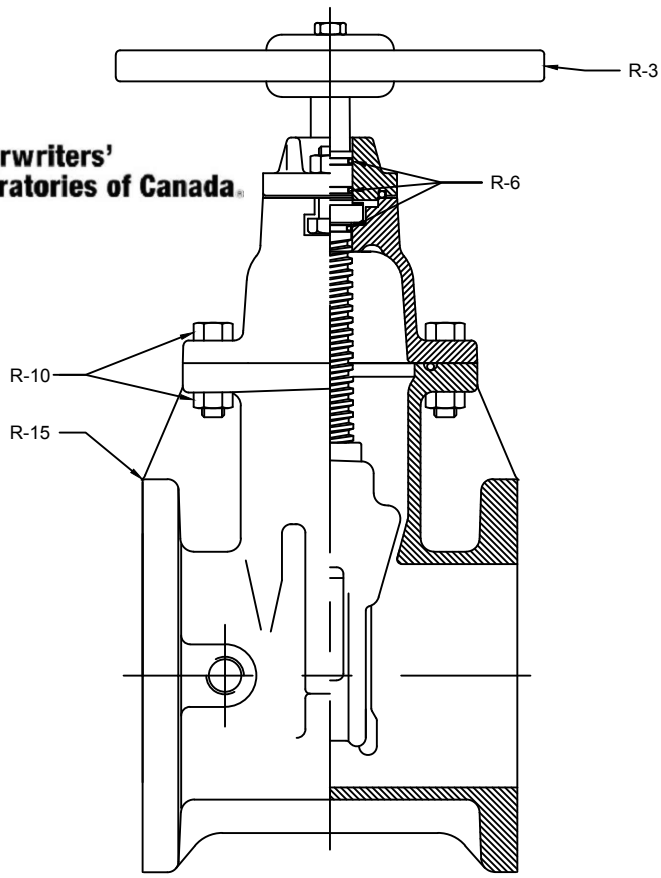

ITEM	DESCRIPTION	MATERIAL	ASTM SPEC.
R-1	HOLD DOWN BOLT	Stainless Steel	ASTM F 593
R-2	BOLT WASHER	Stainless Steel	ASTM F 593
R-3	OPERATING NUT or HANDWHEEL O/L or O/R	Gray Iron	ASTM A126 Cl B
R-4	FOLLOWER BOLTS & NUTS	Stainless Steel	ASTM F 593
R-5	FOLLOWER PLATE 2640	Cast Iron	ASTM 126-B
R-6	STEM O-RING	Buna N	D 2000
R-7	FOLLOWER PLATE O-RING	Buna N	D 2000
R-8	THRUST WASHER	Delrin	DELRIN
R-9	STEM O/L or O/R (867)	Bronze	ASTM B584 C86700
R-10	COVER BOLTS & NUTS	Stainless Steel	ASTM F 593
R-11	COVER	Gray Iron/Ductile	ASTM 126-B/A536
R-12	STEM NUT O/L or O/R	Bronze	ASTM B584 C83600
R-13	WEDGE	Gray Iron & SBR/Ductile SBR	ASTM 126-B/A536
R-14	COVER O RING	Buna N	D 2000
R-15	BODY (ALL TYPES)	Gray Iron/Ductile	ASTM 126-B/A536

R/W VALVE ASSEMBLY BOLT SIZE & TORQUE REQUIREMENTS

VALVE SIZE	FOLLOWER PLATE	QTY	TORQUE	COVER BOLT	QTY	TORQUE
2" - 3"	5/8" x 2 1/2"	2	50	5/8" x 2 1/2"	4	50
4"	5/8" x 2 1/4"	2	100	1/2" x 2" (1 3/4" OK)	4	50
6"	5/8" x 2 1/2"	2	100	5/8" x 2 3/4" (2 1/2" OK)	4	100
8"	5/8" x 3 1/2"	2	100	5/8" x 3 1/4"	8	100
10"	7/8" x 3 1/2"	2	200	5/8" x 3 1/4"	8	100
12"	7/8" x 3 1/2"	2	200	5/8" x 3 3/4"	8	100
14"	7/8" x 3 1/2"	2	200	3/4" x 3 1/2"	12	130
16"	7/8" x 3 1/2"	2	200	3/4" x 3 1/2"	12	130