

390C RESTRAINER ASSEMBLY INSTRUCTIONS

1. Insert pipe into push-on joint bell per pipe manufacturer's instructions.

2. Using the restraint rods as a guide mark a line on each section of pipe one inch less than the restraint rods total length. Place 300C clamps onto pipe aligning outside edge of clamps to marks. Place hex head clamp bolts through clamp ears insuring bolt end threads are exposed. **DO NOT TIGHTEN CLAMPING BOLTS, LEAVE LOOSE.**

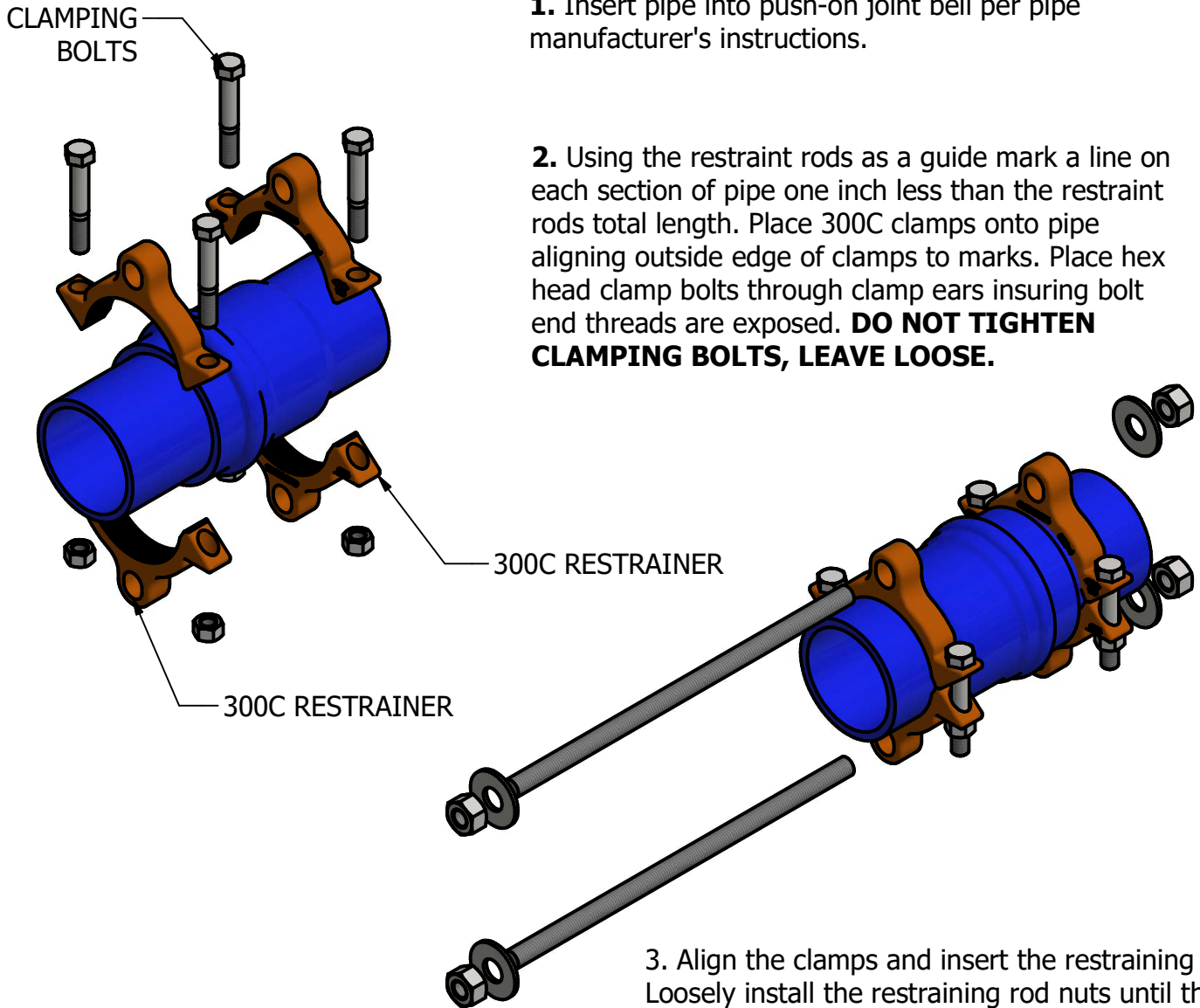

3. Align the clamps and insert the restraining rods. Loosely install the restraining rod nuts until they touch the backside of the clamps. Tighten clamping bolts evenly insuring equal gaps exist between the two halves. Torque clamp bolts to the following torque requirements:

4" - 6" clamps (100 ft-lbs)
8" clamps (150 ft-lbs)
10" - 12" clamps (200 ft-lbs)

4. Complete the installation by tightening the restraining rod nuts until snug.

