

ITEM	DESCRIPTION	# REQ'D	MATERIAL	2 1/2"	3"	4"	6"	8"	10"	12"
R-1	HANDWHEEL NUT	1	BRONZE ASTM B584 C87850 or C87610							
R-2	HANDWHEEL	1	DUCTILE IRON ASTM A536 65-45-12							
R-3	THRUST WASHER	2	BRONZE ASTM B36 <small>2.5" LOWER = DELRIN/VELCON</small>							
R-4	ANTI FRICTION BEARING	1	NYLATRON SIZES 3 - 12"							
R-5	YOKE NUT	1	BRONZE ASTM B584 C86700							
R-6	HEX. HEAD BOLTS		ZINC PLATED STEEL ASTM A307	(4) 1/2-13x2	(4) 1/2-13x2	(4) 1/2-13x1.75	(4) 5/8-11x2.25	(8) 5/8-13x2.5	(8) 5/8-11-2.75	(8) 5/8-11-2.75
	HEX. NUTS		ZINC PLATED STEEL ASTM A563	4) 1/2	4) 1/2	4) 1/2	4) 5/8	8) 1/2	8) 1/2	8) 1/2
R-7	COVER	1	DUCTILE IRON ASTM A536 70-50-5							
R-8	HEX. NUTS	2	BRASS ASTM A563	1/2 HVY HEX	1/2 HVY HEX	1/2 HVY HEX	1/2 HVY HEX	1/2 HVY HEX	5/8 HVY HEX	5/8 HVY HEX
	SQ. HEAD BOLTS	2	ZINC PLATED STEEL ASTM A307	1/2-13X2.75	1/2-13X2.75	1/2-13X2.75	1/2-13X2.75	1/2-13X2.75	5/8-11X3.5	5/8-11X3.5
R-10	GLAND	1	DUCTILE IRON ASTM A536 70-50-5							
R-11	PACKING		SQ. BRAIDED NON-ASBESTOS	(4) 0.31X0.44X5.12	(4) 0.31X0.44X5.12	(4) 0.31X0.44X5.12	(4) 0.31X0.44X5.62	(4) 0.31X0.44X6.00	(4) 0.50X0.50X6.50	(4) 0.50X0.50X6.50
R-12	"O" RING	1	BUNA-N	#2-427	#2-427	#2-437	#2-445	#2-447	#2-452	#2-455
R-13	"O" RING (STEM ASSY)	<small>(1) part of stem assy</small>	BUNA-N	#2-320	#2-320	#2-320	#2-322	#2-324	#2-325	#2-325
R-14	STEM	1	BRASS B371 C69300 OR 304 STAINLESS STEEL							
R-15	EPDM ENCAPSULATED WEDGE	1	DUCTILE IRON ASTM A536 GRADE 70-50-5							
R-16	FLANGED BODY	1	DUCTILE IRON ASTM A536 GRADE 70-50-5							

350 PSI RATED

AWWA

MODEL KS-FWHP MEETS AWWA C509
MODEL KS-RWHP MEETS AWWA C515

ALL FASTENERS US - UN & TO ASTM STANDARDS

SIZE	A	B	C	D	TURNS TO OPEN
* 2 1/2"	8.63	18 7/8"	15 5/8"	10"	10
3"	8.63	18 7/8"	15 5/8"	10"	10
4"	11.75"	22 3/4"	18 1/4"	10"	13 1/2
6"	13.63"	30 1/8"	23 3/4"	12"	19 1/2
8"	14.13"	37 3/4"	29 1/4"	14"	25 1/2
10"	14.30"	45 3/4"	35 3/8"	18"	31 1/2
12"	15.38"	53 1/8"	40 5/8"	18"	37 3/4

* 2 1/2" VALVE IS 3" VALVE WITH 2 1/2" DRILL PATTERN

NOTES:

1. END FLANGES TO ASTM B16.1 CLASS 250.
2. PRESSURE ENVELOPE DUCTILE IRON.
3. WEDGE COMPLETELY ENCAPSULATED.
4. ILLUSTRATION SHOWN IS A HALF SCALE OF A 6" FLG X FLG FIGURE 5168 VALVE.

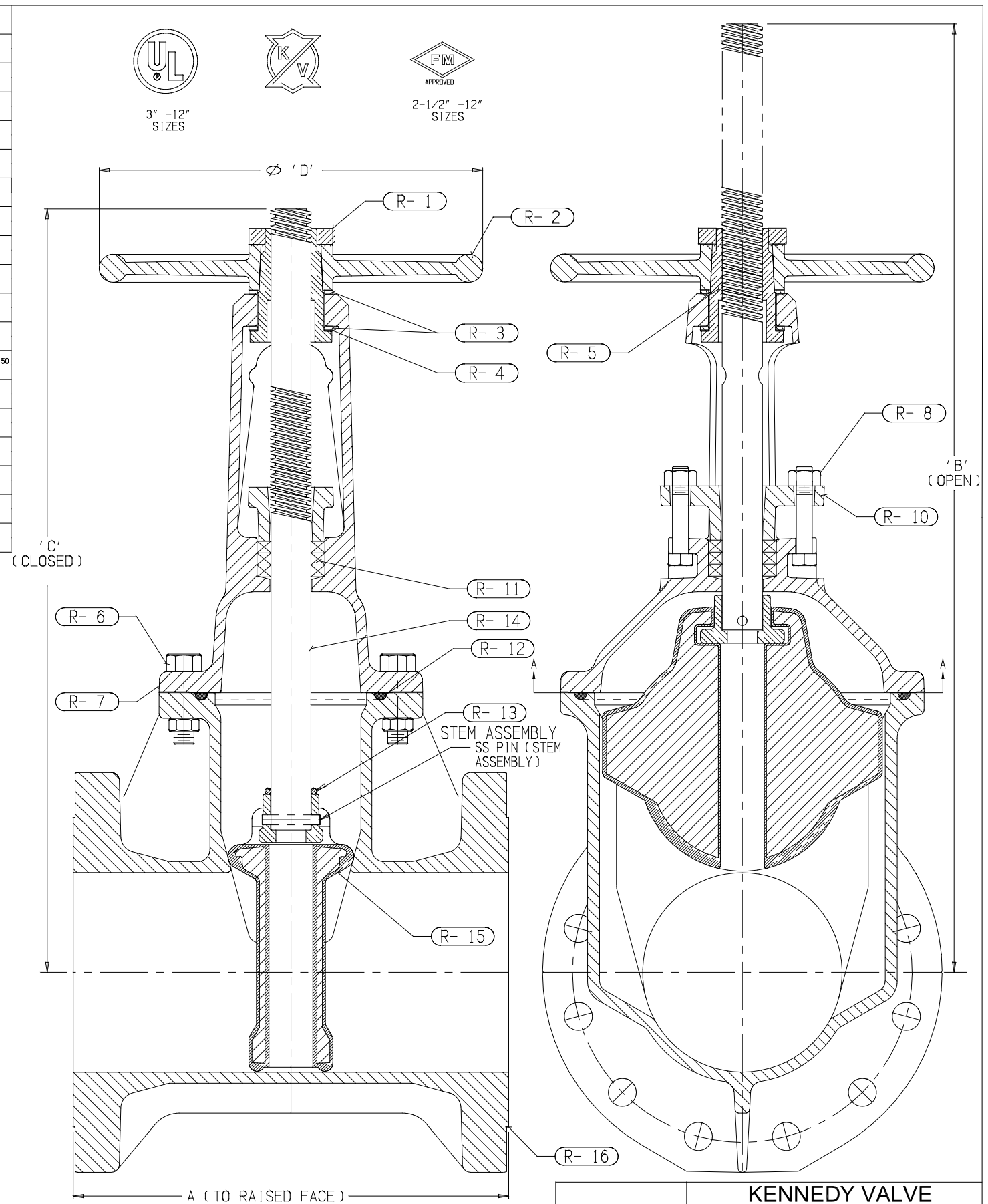

NO.	Date	ECN	REVISION
6	4/15	2927	ADDED MODEL KS-FWHP AND REMOVED KS-300
5	2/15	-	ADDED MODEL KS-RWHP
4	6/05	-	Add 10 & 12" Sizes - Note UL List 2 1/2"-8" Only
3	8/03	-	CLARIFIED TITLE FOR KS300 APPLICATION
2	5/3/02	-	CLARIFIED 2.5" SIZE AND OTHER MISC. NOTES
1	09/00	-	RELEASED FOR PRODUCTION, SUBMIT TO UL 07/01

KENNEDY VALVE	
ELMIRA, N.Y. 14901	
2.5"-3" KS-FWHP & 4"-12" KS-RWHP	
250# FLGS OS&Y ASSY	
FILE PATH	DRAFTDATE
Drawn by: BES	DWG NO. 81345
ISSUED 01SEPTEMBER00	Revision 06