

PROJECT	750 - 1200 R/W VALVE MJ ENDS SPUR GEAR GENERAL DIMENSIONS	
OWNER		
CONTRACTOR		MODEL F6100SG
DISTRIBUTOR		FUSION EPOXY - NSF 61 AND AWWA C550
CONSULTANT		COMPLIES WITH AWWA C515
CLOW CANADA		

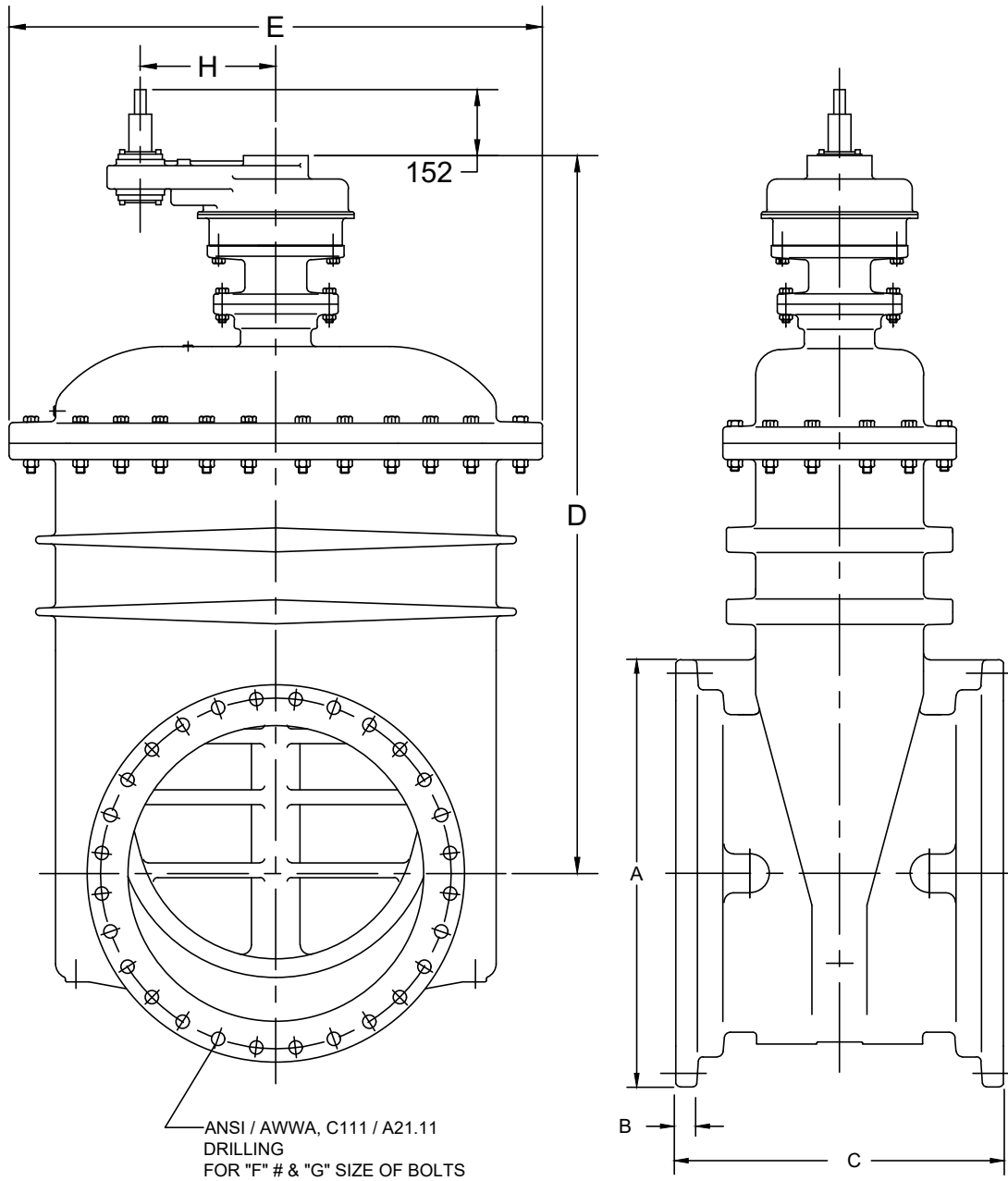

VALVE SIZE	A	B	C	D	E	F	G	H	J
750	1003	45	1232	1883	1390	20	1"	356	51
900	1181	51	984	2126	1495	24	1"	356	32
1050	1372	51	990	2604	1981	28	1 ¼"	406	38
1200	1543	51	1067	2680	1981	32	1 ¼"	406	38