

PROJECT  
 OWNER  
 CONTRACTOR  
 DISTRIBUTOR  
 CONSULTANT

**CLOW CANADA**

**MODEL 2638 750mm-1350mm FLANGED  
 RW GATE VALVE  
 WITH SPUR GEAR**

**F6102 SG**

**FUSION EPOXY - NSF 61 & AWWA C515**

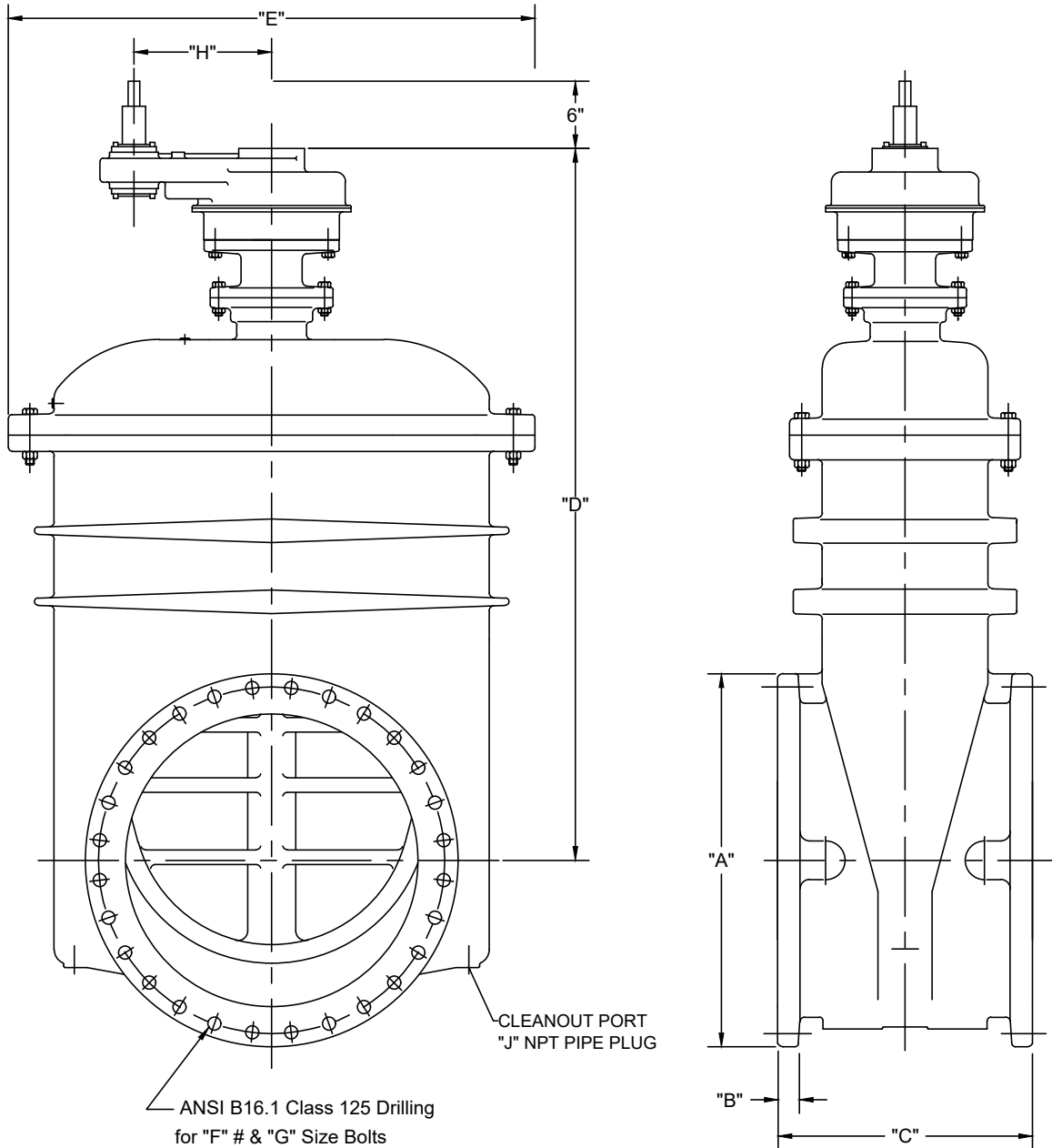

Valve Size	"A"	"B"	"C"	"D"	"E"	"F"	"G"	"H"	"J"
750mm	984	54	1016	1883	1390	28	1-1/4	356	2"
900mm	1168	60	781	2126	1495	32	1-1/2	356	1 1/4"
1050mm	1346	66	914	2604	1981	36	1-1/2	406	1 1/2"
1200mm	1511	70	902	2680	1981	44	1-1/2	406	1 1/2"
1350mm	1683	76	1219	2680	1981	44	1-3/4	406	1 1/2"