

# CLOW CANADA

100mm - 300mm R/W VALVE TYTON ENDS  
NRS GENERAL DIMENSIONS

PROJECT

OWNER

CONTRACTOR

DISTRIBUTOR

CONSULTANT

CLOW FIGURE F6112

CLOW MODEL 2640 AWWA C509 FULL WALL CAST IRON

CLOW MODEL 2639 AWWA C509 FULL WALL DUCTILE IRON

**OPTIONAL**

- 1) HANDWHEEL
- 2) 2" OP. NUT & PI PLATE
- 3) 2" OP. NUT
- 4) RED NUT or H/W = OPEN RIGHT
- 5) BLACK NUT or H/W = OPEN LEFT

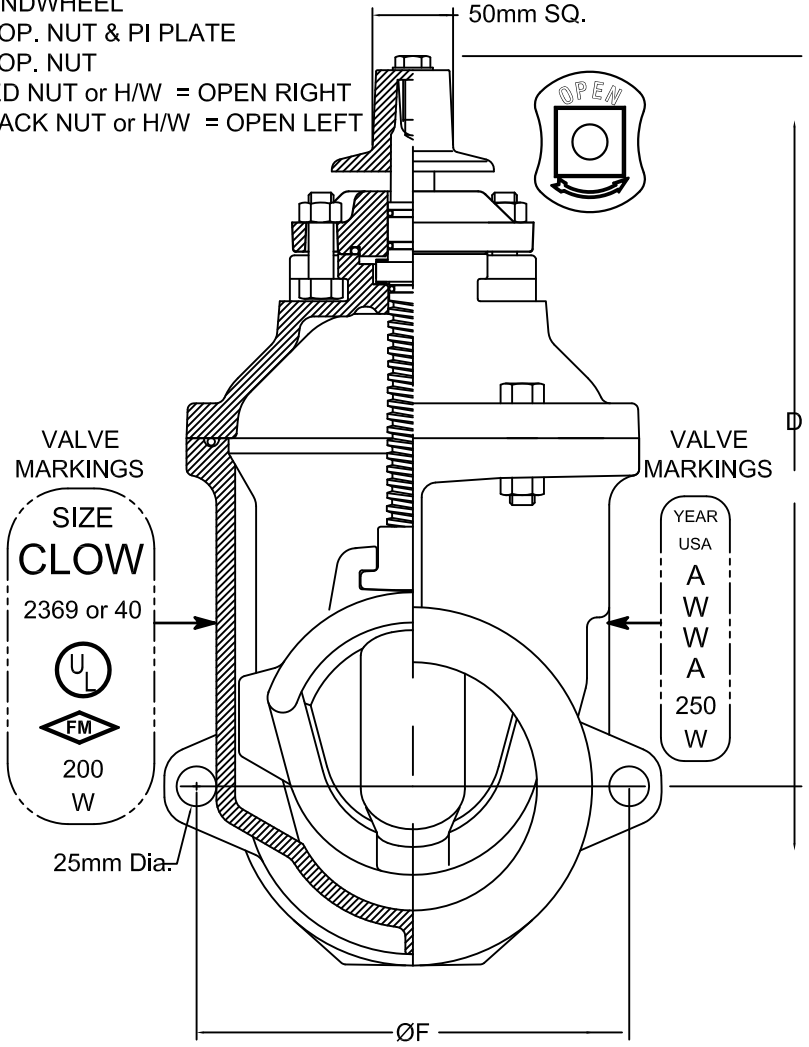
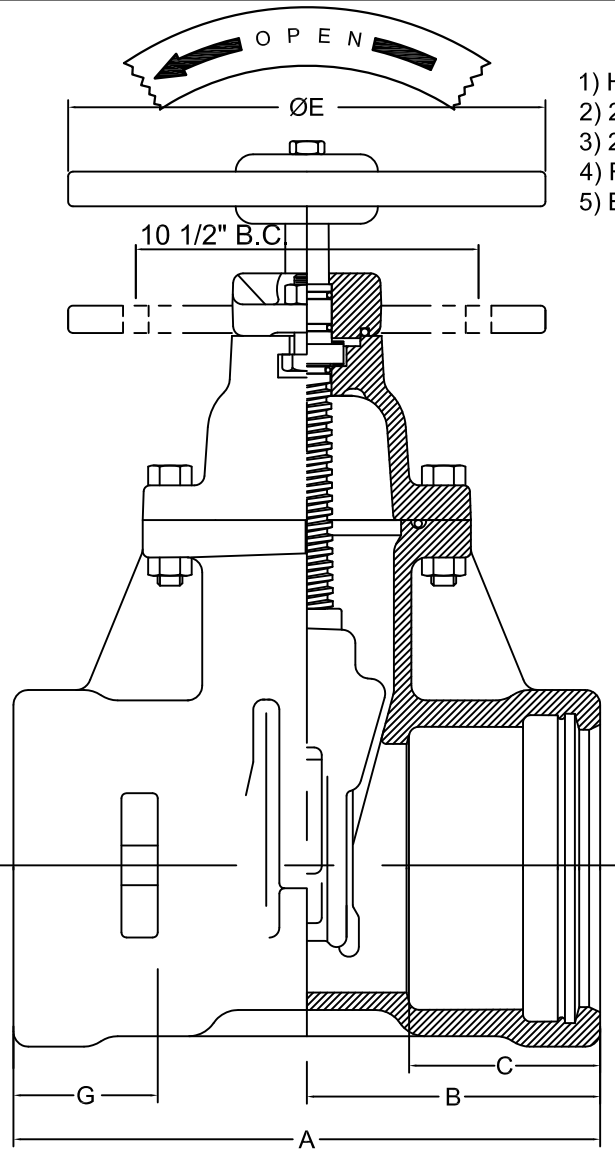

**TYTON ENDS PER ANSI / AWWA C111 / A21.11**



METRIC DIMENSIONS								NUMBER OF TURNS	WEIGHT W/2" NUT	WEIGHT W/ HW	WEIGHT PI PLATE
VALVE SIZE	A	B	C	D	E	F	G				
100	335	165	110	375	250	210	95	13 1/2	87 lbs	93 lbs	103 lbs
150	375	185	120	480	300	275	95	19 1/2	135 lbs	144 lbs	151 lbs
200	435	215	145	570	350	325	115	25 1/2	211 lbs	223 lbs	227 lbs
250	490	245	155	670	450	405	130	31 1/2	355 lbs	374 lbs	371 lbs
300	530	265	155	760	450	470	135	37 3/4	496 lbs	515 lbs	513 lbs